

MARK	REVISIONS NO	REASONABLE RVISIONS	DATE	DWN	APVD

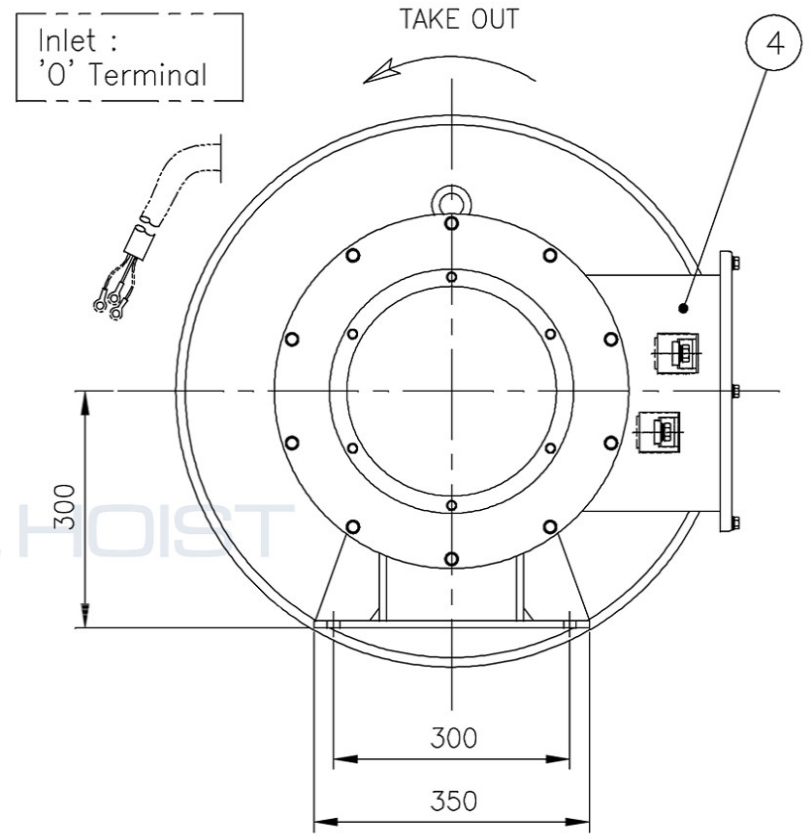
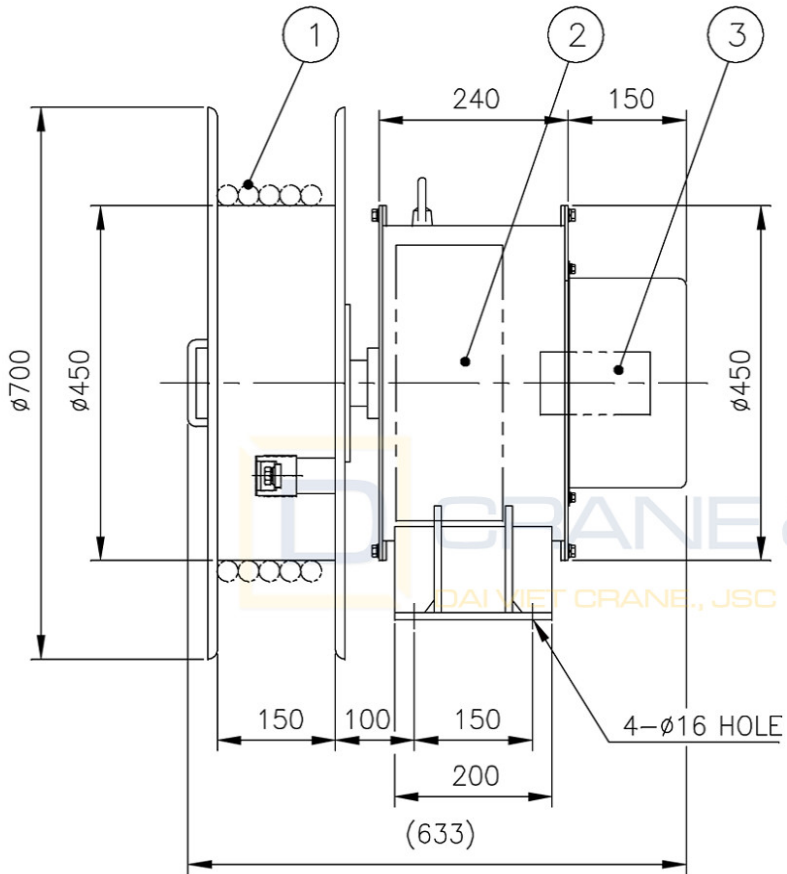
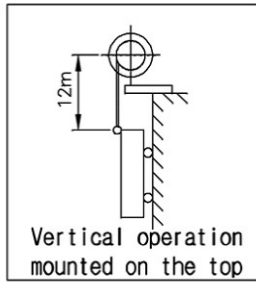
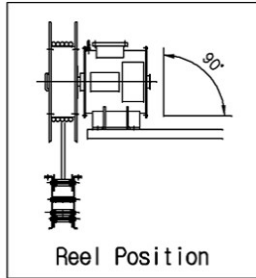
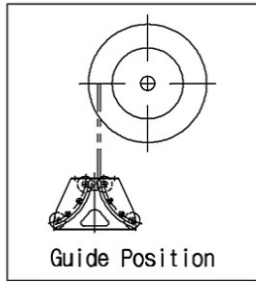

SPECIFICATION

- 1. Cable
 - o PNCT 6 sq x 8c
 - o Size : approx. Ø23.7mm
 - o Weight : approx. 0.84 kg/m
 - o Length : 13 M
- 2. Winding Length : 12 M
- 3. Winding Speed : max. 20 M/MIN
- 4. Winding Torque : 6.0 Kg.m
- 5. Slip Ring : 30A x 8P
- 6. Paint Color : MUNSSELL No. 7.5 BG6/1.5 (Out Door_60um)
- 7. Setting Height : Max. 12 m from G.L.

4	TERMINAL BOX	SPHC	1		
3	SLIP RING	C3771	8		
2	SPRING	SK-5	3		
1	CABLE	PNCT	13M		
ITEM 순번	PARTS NO. 품번	PART NAME 품명	MATERIAL 재질	Q'TY 수량	REMARKS 비고
PROJECTION 3rd ANGLE		DIMENSIONS METRIC (mm)		SCALE 1 : 10	MODEL ECSV-613-8
CUSTOMER 고객			PART NAME CABLE REEL		
MODEL COLOR 제품 색상			PART NO. A455-6000		
DRAWING		DESIGN	CHECK	APPROVAL	
SIGN		C.H.S			
DATE		2019.07.30			



A4(210X297)